



C. C. Series (CLASS I 50V ~ 100V)



Electronic Characteristics

Operating Temperature Range	-30°C to 85°C
Capacitance	Within tolerance at 1MHz and 25 °C
Capacitance Tolerance	0.5 to 10pF: ±25pF, ±0.5pF above 10pF: ±5%, ±10%
Rated Voltage	50, 100 V _{DC} .
Test Voltage	3 times rated voltage for 1.5 sec.
Insulation Resistance	10,000MΩ min at WV _{DC} . 60 sec.

Temperature characteristic curves

NPO - N750

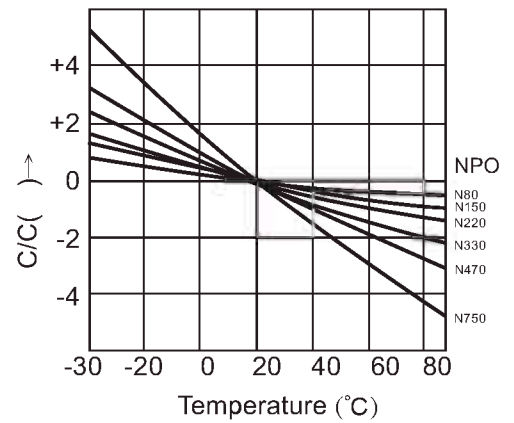

SL (P350) - (N 1000)

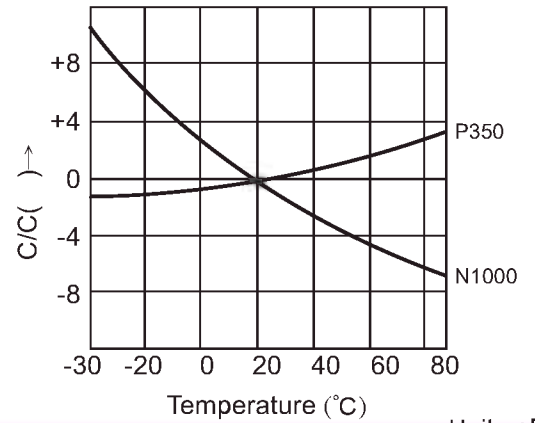

Temperature Coefficient

Code	T. C.	PPM / °C	EIA Code
CH	NPO	0 ± 60	COH
UJ	N750	-750 ± 120	U2J
SL	N330 ± 500	+350 ~ -1000	S2L

Q Factor < 30 PF... Q ≥ 400+20C(c:cap)
> 30 PF... Q ≥ 1000

Life Test 1.5 times rated voltage at 85°C for 500 hrs.

Capacitance Size and Tolerance

T.C	Capacitance	Tolerance	D max (mm)	F (mm)
NPO	0.5 PF	C/D	6	2.5/5.0
	1~9 PF	C/D	6	2.5/5.0
	10~22 PF	J/K	6	2.5/5.0
	23~33 PF	J/K	7	2.5/5.0
	35~47 PF	J/K	8	2.5/5.0
	48~68 PF	J/K	9	5.0
	68~82 PF	J/K	10	5.0
	83~100 PF	J/K	11	5.0
	23~50 PF	J/K	6	2.5/5.0
	51~68 PF	J/K	7	2.5/5.0
	69~130 PF	J/K	8	2.5/5.0
	150~180 PF	J/K	9	5.0

T.C	Capacitance	Tolerance	D max (mm)	F (mm)
NPO	200~220 PF	J/K	10	5.0
	230~330 PF	J/K	11	5.0
	300~330 PF	J/K	13	5.0
N750	10~47 PF	J/K	6	2.5/5.0
	48~68 PF	J/K	7	2.5/5.0
	69~120 PF	J/K	8	2.5/5.0
SL	20~180 PF	J/K	6	2.5/5.0
	181~220 PF	J/K	7	2.5/5.0
	221~390 PF	J/K	8	2.5/5.0
	400~560 PF	J/K	9	5.0
	561~680 PF	J/K	10	5.0
820 PF	J/K	11	5.0	

Unit : pF

C..... : ± 0.25 PF D..... : ± 0.5 PF J..... : ± 5 K..... : ± 10



C.C. Series (CLASS I and CLASS II 500V ~ 15KV)

Electronic Characteristics

Operating Temperature Range

Code	Temp Range	Cap Chang	EIA Code
A	-30°C~+85°C	±4.7%	Y5E
B		±10%	Y5P
E	+10°C~+85°C	+22%~-56%	Z5U
F		+22%~-82%	Z5V

Capacitance

Within tolerance at 1KHz and 25°C

Capacitance tolerance :

TEMP. CHAR.	CAP. TOL.
Y5E	± 10%
Y5P	± 10%
Z5U	± 20%
Z5V	+80%~-20%

Rated Voltage

500V_{dc}~15KV_{dc}

Test Voltage

Below 1KV : 300%
 1KV 2KV. 200%
 2KV < W. V. ≤ 5KV for 175%
 5KV < W. V. ≤ 15KV for 150%
 rated voltage with 50mA
 max charging current for
 2.5 sec.

Insulation Resistance

10,000MΩ min at WV_{dc}.

Dissipation Factor

2.5%max for Y5E, Y5P at 1KHz and 25°C
 3.5%max for Z5U, Z5V at 1KHz and 25°C

Life Test

1.5 times working voltage at 85°C
 for 500 hours.



Temperature characteristic curves

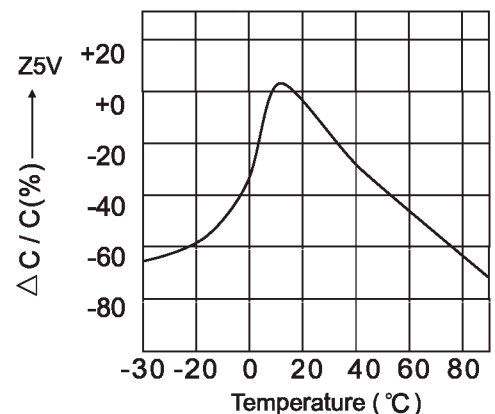
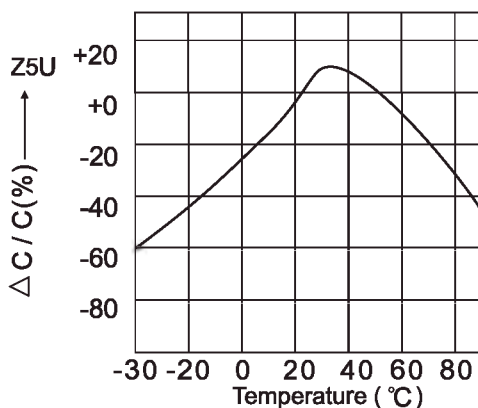
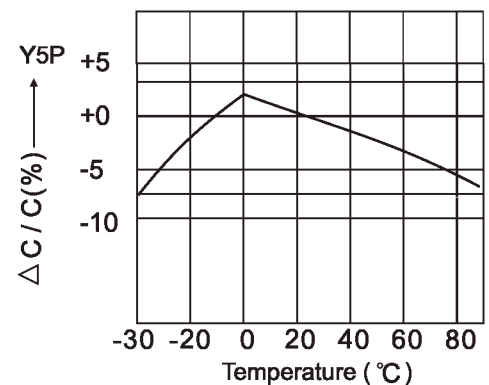
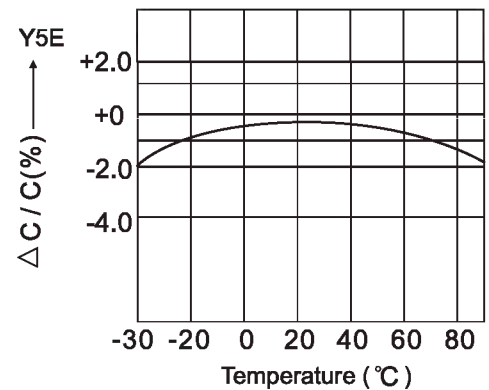



C.C. Series (CLASS I and CLASS II 500V ~ 15KV)

Unit: pF

	NPO	SL	Y5E A Y5P B	E Z5U	F Z5V	DIAMETER MAX (mm)
500V	010 ~330	—	~102	~222	~392	6
	~390	~820	~122	~332	~502	7
	~470	~101	~182	~502	~562	8
	~820	~161	~222	~682	~103	9
	~121	~221	~332	~822	~153	10
	~161	~301	~472	~103	~183	11
	~241	~431	~682	~153	~223	13
	—	~561	~103	~223	~333	15
	—	—	—	~333	~473	17
	—	—	—	—	~104	19
1KV	010 ~200	~330	~501	~102	~122	6
	~330	~680	~102	~222	~182	7
	~560	~101	~152	~272	~222	8
	~680	~221	~182	~392	~332	9
	~820	~271	~222	~562	~103	10
	~101	~331	~332	~103	~123	11
	~121	~471	~472	~153	~183	13
	~221	~681	~682	~223	~223	15
	—	—	~103	~333	~473	17
	—	—	—	—	104	19
2KV	010 ~220	—	—	—	—	6
	~330	~470	~561	~122	~182	7
	~470	~820	~681	~182	~222	8
	~560	~101	~102	~272	~332	9
	~680	~151	~152	~332	~472	10
	~121	~221	~222	~472	~682	11
	~151	~331	~332	~562	~103	13
	—	~391	~562	~103	~183	15
	—	—	~822	~153	~203	17
	—	—	—	—	—	—
3KV	010 ~120	~390	—	—	—	6
	~200	~560	~471	~122	~182	7
	~270	~820	~681	~182	~222	8
	~330	~121	~821	~222	~272	9
	~470	~221	~122	~272	~472	10
	~680	~331	~152	~392	~562	11
	~750	~471	~222	~562	~682	13
	~101	—	~332	~682	~822	15
	~151	—	~472	~103	~103	17
	—	—	—	—	—	—

Above is for reference only. Sizes are subject to change w/o notice.



C.C. Series (CLASS I and CLASS II 500V ~ 15KV)

Unit: pF

	NPO	SL	Y5E A Y5P B	E Z5U	F Z5V	DIAMETER MAX (mm)
4KV	010 ~150	~470	~471	~102	~202	7
	~220	~680	~561	~152	~272	8
	~330	~101	~102	~272	~472	10
	~560	~151	~152	~392	~682	13
	~820	~271	~222	~682	~103	15
	~121	~391	~332	~103	~153	17
6.3KV	010 ~120	~390	~391	~102	~152	8
	~220	~680	~681	~202	~302	10
	~330	~101	~122	~302	~472	11
	~470	~151	~182	~402	~682	13
	~680	~221	~222	~562	~822	17
	~101	~331	~332	~822	~103	19
8KV	010 ~100	~390	~391	~102	~152	8
	~220	~680	~681	~202	~302	10
	~330	~101	~122	~302	~472	11
	~470	~151	~182	~402	~682	13
	~680	~221	~222	~562	~822	17
	~101	~331	~332	~822	~103	19
10KV	010 ~060	~150	~201	~471	~821	10
	~100	~300	~391	~102	~152	11
	~180	~470	~681	~152	~222	13
	~270	~750	~102	~222	~332	17
	~390	~121	~152	~392	~562	19
15KV	010 ~050	~150	~221	~471	~821	8
	~080	~220	~301	~751	~122	10
	~120	~330	~471	~122	~182	11
	~180	~470	~681	~182	~272	13
	~300	~820	~102	~272	~392	17

Above is for reference only. Sizes are subject to change w/o notice.



C. C. Series (CLASS II 50V~100V)

Electronic Characteristics

Operating Temperature Range			
Cod	Temp Range	Cap Chang	EIA Code
A	-30°C ~ +85°C	± 4.7 %	Y5E
B		± 10 %	Y5P
E	+10°C ~ +85°C	+ 22% ~ -56%	Z5U
F		- 22% ~ -82%	Z5V

Capacitance Size and Tolerance

Capacitance	Within tolerance at 1 KHz and 25°C
Capacitance tolerance:	
TEMP. CHAR.	CAP. TOL.
Y5E	10%
Y5P	10%
Z5U	20%
Z5V	+80 ~ -20%
Rated Voltage	50, 100VDC
Test Voltage	2.5 times rated voltage for 1.5 sec less than 50mA
Insulation Resistance	10,000MΩ min at WVDC .
Dissipation Factor	2.5 max for Y5E, Y5P at 1 KHz and 25 °C. 3.5 max for Z5U, Z5V at 1 KHz and 25 °C.
Life Test	1.5 times working voltage at 85°C for 500 hours.

Capacitance Size and Tolerance

H.K. Type	Capacitance (pF)	Tolerance	D max (mm)	Foot Distance (mm)
Y5P	100-680	K/M	6	2.5/5.0
	821-2200	K/M	6	2.5/5.0
	2200-3300	K/M	7	2.5/5.0
	3300-4700	K/M	8	2.5/5.0
	4700-6800	K/M	9	5.0
	6800-10000	K/M	10	5.0
Z5U	0.1uF	K/M	10,11	5.0
	1000-5000	M/Z	6	2.5/5.0
Z5V	5001-10000	M/Z	7	2.5/5.0
	2700-10000	Z	6	2.5/5.0
Z5V	0.015-0.022uF	Z	7	2.5/5.0

K.....±10% M.....+20% Z.....+ 80%~-20%

Temperature characteristic curves

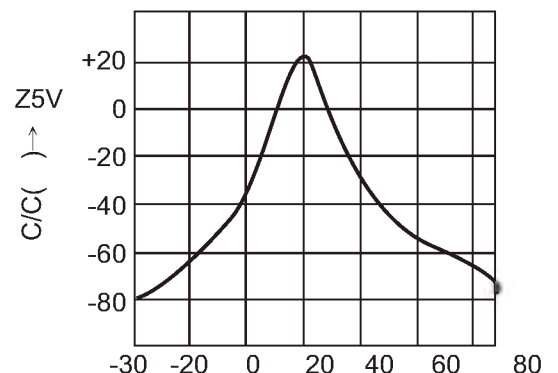
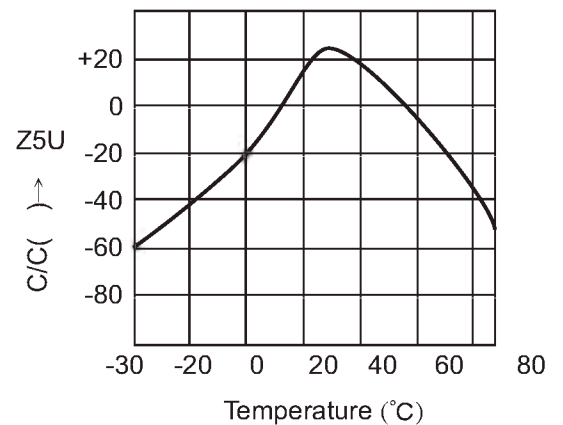
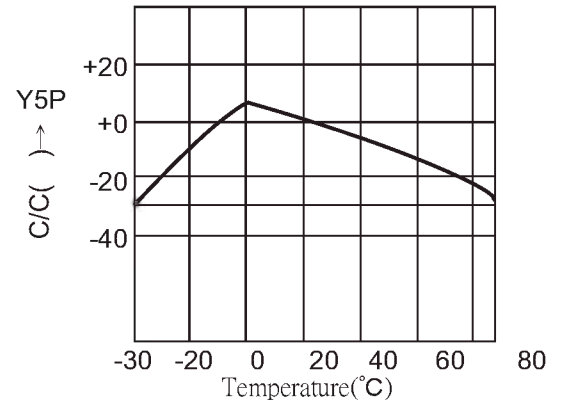
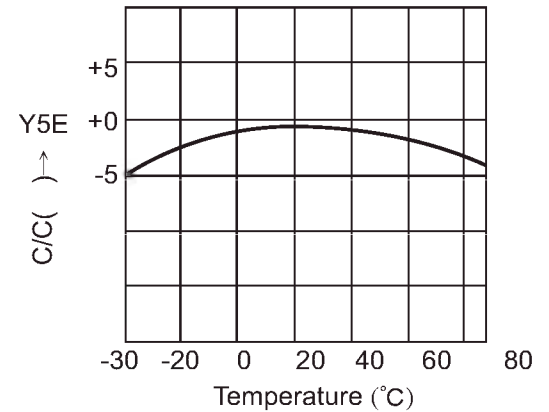



C. C. Series (CLASS III 25V ~ 50V)

Temperature characteristic curves

Electronic Characteristics

Operating Temperature Range	-30°C to +85°C
Capacitance	Within tolerance at 1 KHz and 25? (lever 0.1 V rms max)
Capacitance Tolerance	± 10 , ± 20 , +80% ~-20%
Rated Voltage	25, 50V _{DC} .
Test Voltage	2 times rated voltage for 1.5 sec
Insulation Resistance	1000MΩ at 10 V for 1 minute. (25 ~ 50 V)

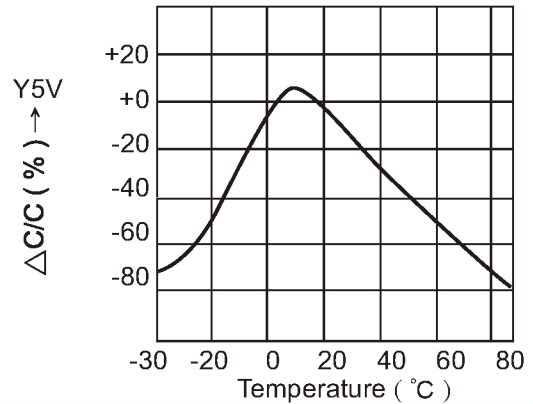
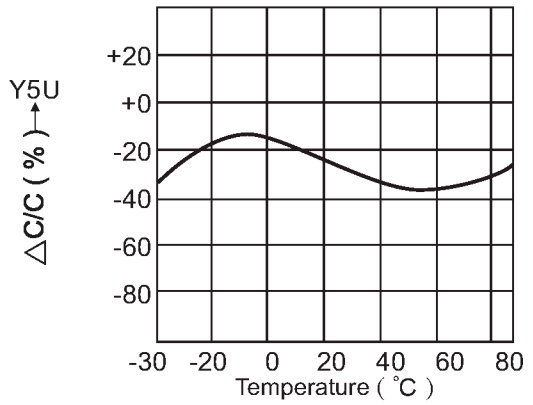
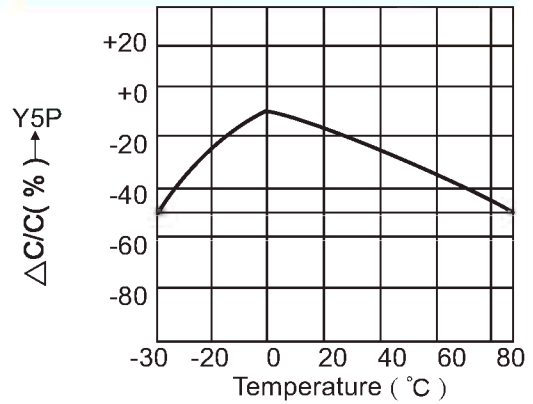

Characteristics at Temperature

Code	Temp. Range	Cap. Change	EIA. Code
B	-30°C ~ +85°C	±10	Y5P
E		+22 ~ -56 %	Y5U
F		+22 ~ -82%	Y5V

Dissipation Factor	5% max for 25~ 50 V at 1 KHz.
Life Test	Apply rated voltage at 85°C for 500 hours.

Capacitance Size and Tolerance

Unit : μF

	S. C. Type	Capacitance (μ F)	Tolerance	D Max (mm)	F (mm)
25 V	Y5P	0.0039 ~ 0.01	K/M	6	2.5 / 5.0
	Y5U	0.015 ~ 0.05	M/Z	6	2.5 / 5.0
		0.068 ~ 0.1	M/Z	7,8	2.5 / 5.0
	Y5V	0.015 ~ 0.022	Z	5	2.5 / 5.0
		0.033 ~ 0.05	Z	6	2.5 / 5.0
		0.068 ~ 0.1	Z	7,8	2.5 / 5.0

	S. C. Type	Capacitance (μ F)	Tolerance	D Max (mm)	F (mm)
50 V	Y5P	0.0039 ~ 0.01	K/M	6	2.5 / 5.0
	Y5U	0.015 ~ 0.05	M/Z	6	2.5 / 5.0
		0.068 ~ 0.1	M/Z	8	2.5 / 5.0
	Y5V	0.015 ~ 0.022	Z	5	2.5 / 5.0
		0.033 ~ 0.05	Z	6	2.5 / 5.0
		0.068 ~ 0.1	Z	8	2.5 / 5.0

K.....+10% M.....±20% Z.....+80%~-20%



CLASS 1, 2, 3 / TAPING SPECIFICATIONS

Taping (Radial)

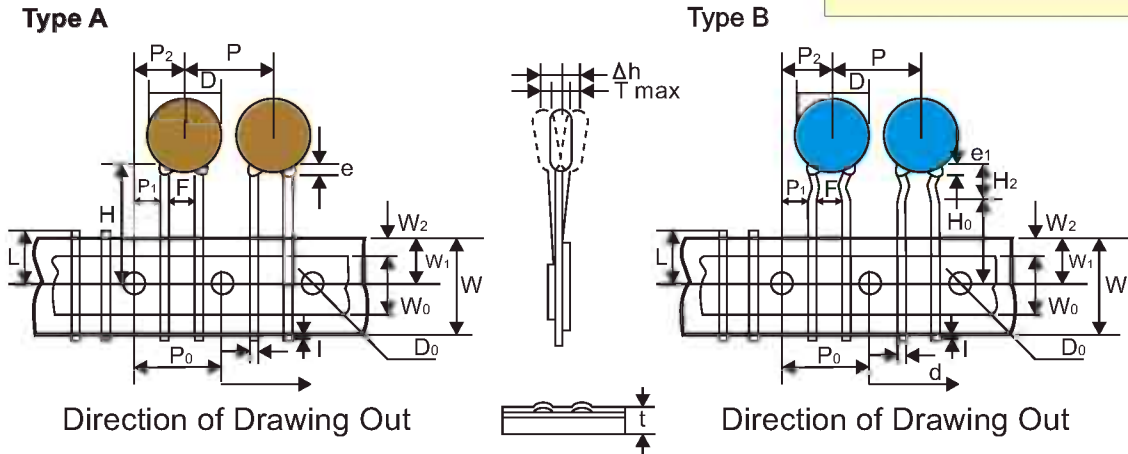
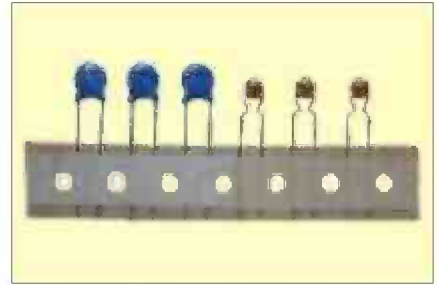

(Unit : mm)

Item	Code	Dimensions (mm)	Item	Code	Dimensions (mm)
Taping Pitch	P	12.7 ± 1.0	Lead Protrusion	I	+0.5~1.0
Guide Pitch	P ₀	12.7 ± 1.0	Diameter of Feed Hole	D ₀	4.0 ± 0.3
Lead Spacing	F	5.0 ± 0.8	Diameter of Lead	d	0.6 ^{+0.06} _{-0.05}
Feed Hold Position Capacitor Body	P ₂	6.35 ± 1.3	Total Thickness of Tape	t	0.7 ± 0.2
Feed Hold Position Capacitor Lead	P ₁	3.85 ± 0.7	Thickness of Capacitor Body	T	3.5
Diameter of Disc	D	See table of each series	Alignment to ER Direction	Δh	0 ± 2.0
			Length of Snipped Lead	L	11.0 ⁺⁰ _{-0.1}
Width of Base Tape	W	18.0 ± 0.5	Width of Hold-down Tape	W ₀	12.5
Feed Hole Vertical Position	W ₁	9.10 ^{+0.75} _{-0.05}	Hold-down Tape Position	W ₂	1.5 ± 1.5
Taping Height	For Straight	H ₀	Coating Extension	e	1.5
	For Crimp	H	Coating Extension	e ₁	up to center of crimp
		20 ^{+1.5} _{-1.0}			

AMMO PACK

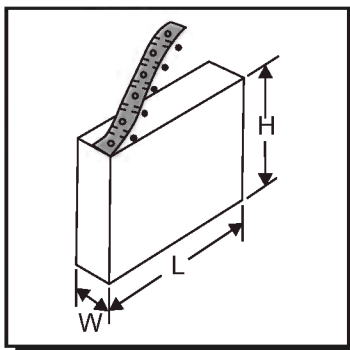

H = 241 ± 5 mm
L = 332 ± 5 mm
W = 42 ± 3 mm

Acceptable to standard radial type cartridge

REEL

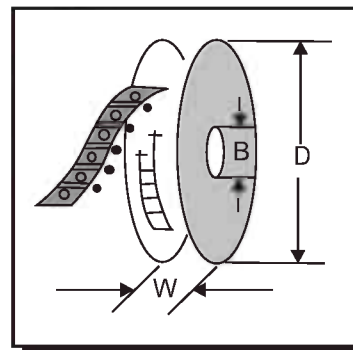

D ≤ 354 (13.93)
B ≤ 21 (.83") but
≤ 30 (1.18")
W ≤ 55 (2.16)

Acceptable to standard radial type cartridge with a few extra accessories. Reeled axials also acceptable to standard axial type cartridge with a few accessories.



MODEL & SPECIFICATION OF CERAMIC CAPACITOR

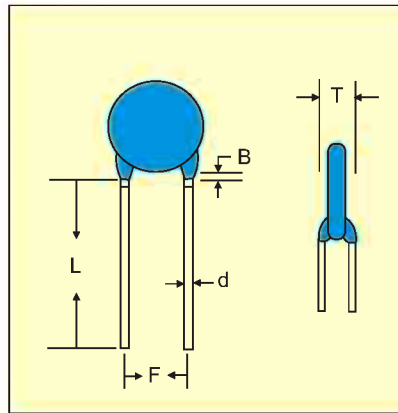

TYPE : A1

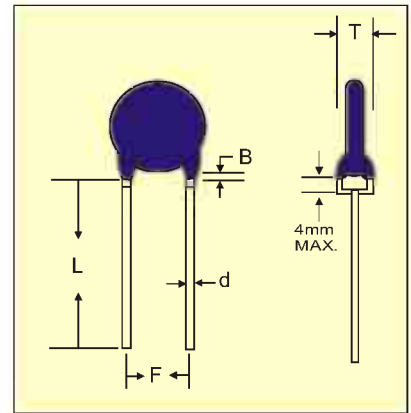

TYPE : A2

	MODEL	W. V.	T m/m	d m/m	L m/m	F m/m	B m/m
Y2	A1	AC 125V ~ 250V AC 400V	5 max	0.6 ±0.06	5 ~ 25	7.5 ±0.8 or 9.52 ±0.8	3 max
	A2	AC 125V ~ 250V AC 400V	5 max	0.6 ±0.06	5 ~ 25	7.5 ±0.8 or 9.52 ±0.8	4 max
	MODEL	W. V.	T m/m	d m/m	L m/m	F m/m	B m/m
Y1	A1	AC 125V ~ 250V AC 400V	8 max	0.6 ±0.06	5 ~ 25	9.52 ±0.8	3 max
	A2	AC 125V ~ 250V AC 400V	8 max	0.6 ±0.06	5 ~ 25	9.52 ±0.8	4 max



According as customer's request and size.

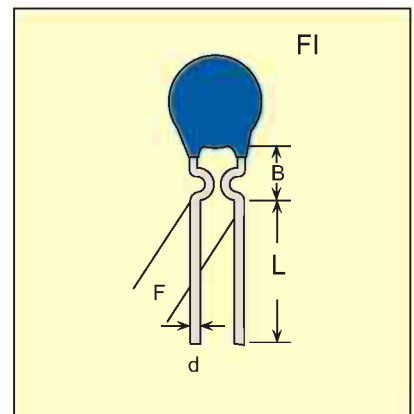
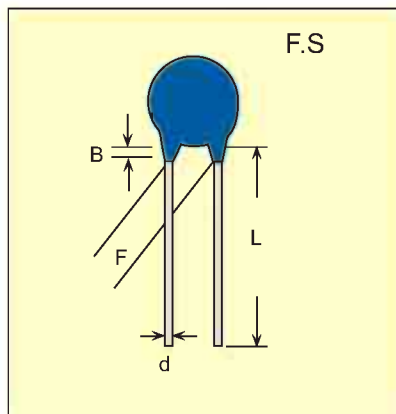
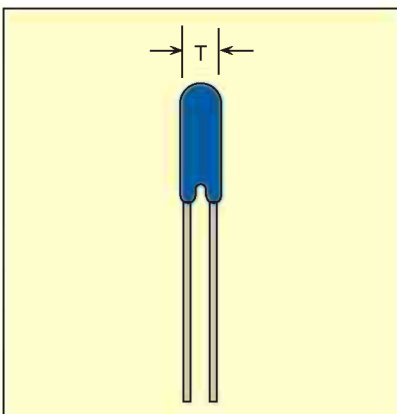



MULTILAYER CERAMIC CAPACITORS

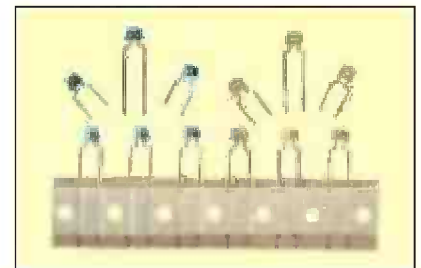
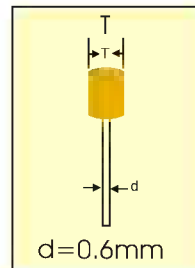
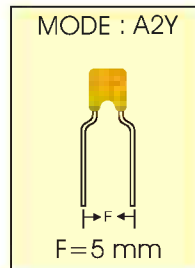
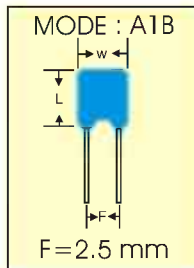

SIZE CODE AND DIMENSIONS : Units in Inches (millimeter)

SIZE CODE	L	W	T	LEAD DIAMETER(d)	LEAD LENGTH(L)	LEAD SPACING(F)	LEAD STYLES
R15	.150 (3.81)	.150 (3.81)	.100 (2.54)	0.024 (0.60)	.10(2.50) 1.0)25.0(.100(2.54)	A1
						.200(5.08)	A2
						.300(7.62)	A2
R20	.200 (5.08)	.200 (5.08)	.125 (3.18)	0.024 (0.60)	.10(2.50) 1.0)25.0(.100(2.50)	A1
						.200(5.08)	A2
						.250(6.35)	A2
						.300(7.62)	A2
R30	.300 (7.62)	.300 (7.62)	.150 (2.18)	0.024 (0.60)	.10(2.50) 1.0)25.0(.200(5.08)	A2
						.300(7.62)	A2

ELECTRICAL SPECIFICATIONS

Capacitance Range: 1pF to 10 μF
 Capacitance Tolerance: (Standard)
 NPO: F = ± 1%

G = ± 2%
 C = ± 0.25pF)10pF and below(
 D = ± 0.5pF)10pF and below(
 J = ± 5%)10pF and above(
 K = ± 10% (5.6pF and above)
 M = ± 20%)2.7pF and above(
 X7R : K = ± 10%

M = ± 20%
 Z = + 80-20%

Working Voltage : 25,50,100,200,1k VDC
 Temperature Characteristic:
 NPO : 0 ± 30ppm°C, -55°C to +125°C
 X7R : ± 15% °C, -55°C to +125°C
 Z5U : + 22% to -56 °C, +10°C to 85°C
 Y5V : + 22% to -82% °C, -30°C to 85°C

Insulation Resistance: at 25°C
 NPO,X7R : 100K Megohms or 1000 Megohms-
 Microfarads whichever is less at
 rated voltage within 2 minutes of
 charging.

Z5U,Y5V : 10K Megohms or 1000 Megohms-
 Microfarads whichever is less at
 rated voltage within 2 minutes of
 charging.

MECHANICAL SPECIFICATIONS

Cast : Conformal coated (epoxy)
 Lead Material : Solder coated, copper
 Package Method : Bulk, Tape & Ammo pack,
 Solder ability : (MIL-STD-202 Method 208)
 Leach Resistance : Temp 230°C, 20seconds
 immersion in Sn62

*STANDARD TOLERANCE

NPO: J. K.
 X7R : K. M.
 Z5U,Y5V : M. Z.

Capacitance Test at 25 °C or referred to +25 °C :
 NPO,X7R.
 1.0 V RMS ± 0.25 VRMS and 1 KHz;
 1 MHz for values below 100pF,
 Z5U,Y5V : 0.5 ± 0.1VRMS maximum and 1KHz.

Dissipation Factor:

N PO : 0.1% maximum at 25 °C, 1.0VRMS
 ± 0.25 VRMS and 1 KHz, 1 MHz for
 values below 100pF

X7R : 2.5% maximum at 25 °C, 1.0VRMS
 ± 0.25 VRMS and 1 KHz.

Z5U,Y5V : 4% maximum at 25 °C, 0.5 ± 0.1VRMS
 maximum and 1 KHz.

Dielectric Strength :

NPO, X7R : 250% rated voltage with 50 mA
 maximum charging current.

Z5U, Y5V : 200% rated voltage with 50 mA
 maximum charging current.

Life Test : (1000 hrs)

NPO, X7R : 200% rated voltage at +125 °C
 Z5U, Y5V : 150% rated voltage at +85 °C

Humidity Resistance:

(MIL-STD-202 Method 106)
 NPO,X7R,Z5U:96 hrs 40 °C relative
 humidity 90-95%

Thermal Shock :

(MIL-STD-202 Method 107, condition A)

Taping
 (CC)Taping



CAPACITANCE RANGE OF MONO RADIAL

T. C.		NPO						X7R						Z5U,Y5V					
SIZE		R15		R20		R30		R15		R20		R30		R15		R20		R30	
CAP	WVDC	50	100	50	100	50	100	50	100	50	100	50	100	50	100	50	100	50	100
		1RF to 100	1R0 to 101	█	█														
120	121	█		█	█														
150	151	█		█															
180	181	█		█															
220	221	█						█	█	█	█								
270	271	█						█	█	█	█								
330	331	█						█	█	█	█								
390	391	█						█	█	█	█								
470	471	█						█	█	█	█								
560	561	█						█	█	█	█								
680	681	█						█	█	█	█								
820	821	█						█	█	█	█			█	█				
1000	102	█						█	█	█	█			█	█				
1200	122	█						█	█	█	█			█	█				
1500	152	█						█	█	█	█			█	█				
1800	182	█						█	█	█	█			█	█				
2200	222	█						█	█	█	█			█	█				
2700	272	█						█	█	█	█			█	█				
3300	332	█						█	█	█	█			█	█				
3900	392							█	█	█	█			█	█				
4700	472							█	█	█	█			█	█				
5600	562							█	█	█	█			█	█				
6800	682							█	█	█	█			█	█				
8200	822							█	█	█	█			█	█				
0.01 μF	103					█		█	█	█	█			█	█				
0.012	123					█		█	█	█	█			█	█				
0.015	153					█		█	█	█	█			█	█				
0.018	183					█		█	█	█	█			█	█				
0.22	223							█	█	█	█			█	█				
0.027	273							█	█	█	█			█	█				
0.033	333							█	█	█	█			█	█				
0.039	393							█	█	█	█			█	█				
0.047	473							█	█	█	█			█	█				
0.056	563							█	█	█	█			█	█				
0.068	683							█	█	█	█			█	█				
0.082	823							█	█	█	█			█	█				
0.10 μF	104							█	█	█	█			█	█				
0.12	124							█	█	█	█			█	█				
0.15	154							█	█	█	█			█	█				
0.18	184							█	█	█	█			█	█				
0.22	224							█	█	█	█			█	█				
0.33	334							█	█	█	█			█	█			█	█
0.47	474							█	█	█	█			█	█			█	█
0.56	564							█	█	█	█			█	█			█	█
0.68	684							█	█	█	█			█	█			█	█
0.82	824							█	█	█	█			█	█			█	█
1.00	105							█	█	█	█			█	█			█	█
1.50	155							█	█	█	█			█	█			█	█
2.20	225							█	█	█	█			█	█			█	█



Y1X1 SERIES

INTRODUCTION:

These Ceramic Disc Capacitors are specifically designed for AC applications and meet the safety requirements of various safety standards agencies.

These capacitors are ideal for across the line and line by-pass applications

FEATURES:

- Ideal for across the line applications
- Compact size
- Cost effective product
- Safety standards recognized for AC applications

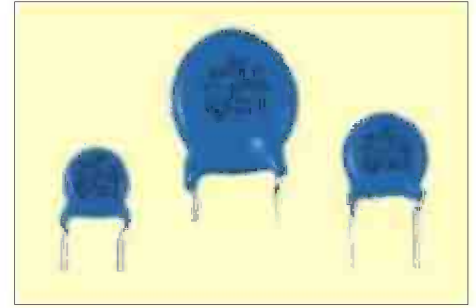

GENERAL SPECIFICATIONS:

Operating temperature range :	-25 C to 85 C
Capacitance range :	10 pF to 4700 pF
Capacitance tolerance :	K= $\pm 10\%$, M = $\pm 20\%$
Rated voltage :	400 V AC. Please refer to table for approval file number.
Temperature coefficient :	$\pm 10\%$ for B (Y5P), +20 to -55% for E (Y5U)
Dissipation factor (tan δ) :	Y5P : 2.5% max. at 25 C and 1KHz, $1 \pm 0.2V_{rms}$. Y5U : 2.5% max. at 25 C and 1KHz, $1 \pm 0.2V_{rms}$.
Insulation resistance at 25 C :	10000 M Ω at 500 V DC for 1 minute.
Dielectric strength :	4000 V AC for 60 seconds - AC 400 V

CAPACITANCE AND DIMENSIONS :

When ordering safety standard recognized ceramic capacitors please use the part numbers as noted below :

Rated : 400V AC for Y1

PART NUMBER	T. C.	CAP.	TOL.	DIMENSION (mm)		
				D max	F	T max
JD10KY5P Y1	$\pm 10\%$ (Y5P)	10PF	K $\pm 10\%$	7	9.5 ± 0.8	7
to		to		7	9.5 ± 0.8	7
JD82KY5P Y1		82PF		7	9.5 ± 0.8	7
JD101KY5P Y1		100PF		7	9.5 ± 0.8	7
JD151KY5P Y1		150PF		7	9.5 ± 0.8	7
JD221KY5P Y1		220PF		8	9.5 ± 0.8	7
JD331KY5P Y1		330PF		8	9.5 ± 0.8	7
JD471KY5P Y1		470PF		7	9.5 ± 0.8	7
JD561KY5P Y1		560PF		8.5	9.5 ± 0.8	7
JD681KY5P Y1		680PF		9.5	9.5 ± 0.8	7
JD102KY5P Y1		1000PF		12	9.5 ± 0.8	7
JD102KY5U Y1	+22~-56% (Y5U)	1000PF	M $\pm 20\%$	9	9.5 ± 0.8	7
JD471MY5U Y1		470PF		7	9.5 ± 0.8	7
JD561MY5U Y1		560PF		8	9.5 ± 0.8	7
JD681MY5U Y1		680PF		8	9.5 ± 0.8	7
JD102MY5U Y1		1000PF		8	9.5 ± 0.8	7
JD152MY5U Y1		1500PF		9	9.5 ± 0.8	7
JD222MY5U Y1		2200PF		11	9.5 ± 0.8	7
JD332MY5U Y1		3300PF		13	9.5 ± 0.8	7
JD392MY5U Y1		3900PF		14	9.5 ± 0.8	7
JD472MY5U Y1		4700PF		15	9.5 ± 0.8	7

Dimensions and Tolerance

B = 3.0 mm max for AA or 4.0 mm max for A2
d = 0.60 mm ± 0.05 mm
F = 9.5 ± 0.8 mm
L = 5~25 mm

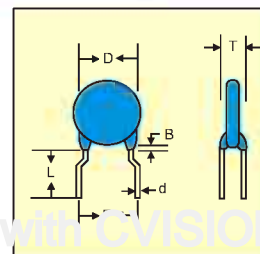

TYPE:AA

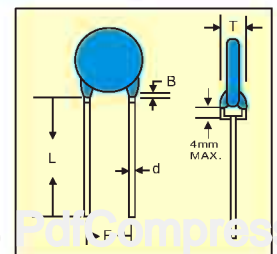

TYPE:A2



Y1,X1 AC 400 V



AC. CAPACITORS

Y1, X1 Series

Applications :

- For use in circuit where alternating, pulsating, intermittent and steady high voltage exist.

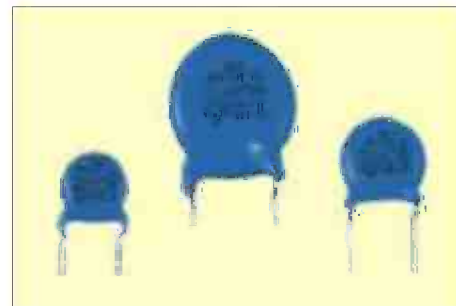

Approved / Recognized Type

Related standard		Certificate No.	Approved Monogram
CSA (Canada)	CSA-22.2 No. 1-98	E 187963	
UL (USA)	UL 1414		
VDE (Germany)	EN 132 400 / IEC 60384-14 (VDE 0565 Teil 1-1)	137027	
SEMKO (Sweden)	EN 132 400 / IEC 60384-14	0137189 / 01-02	
SEV (Switzerland)	EN 132 400 / IEC 60384-14	01.0984	
FIMKO (Finland)	EN 132 400 / IEC 60384-14	17334	
NEMKO (Norway)	EN 132 400 / IEC 60384-14	200104246	
DEMKO (Denmark)	EN 132 400 / IEC 60384-14	310971-01	
NEMKO CB	IEC 60384-14 Table II 2nd (1993)	12607	

Part Number Configuration :

<u>JD</u>	<u>102</u>	<u>K</u>	<u>Y5P</u>	<u>Y1</u>	(1) AC capacitors, safety	(4) Type code : Y5P, Y5U
(1)	(2)	(3)	(4)	(5)	(2) Rated capacitance	(5) Class Y1
					(3) Tolerance on rated capacitance	

Specifications :

Operating Temp. Range	- 25 °C ~ + 85 °C		
Rated Voltage	Applicable Standards		X1 Y1
	CSA, UL		250 V AC
Dielectric Withstanding Voltage	SEMKO, SEV, FIMKO, NEMKO, DEMKO, VDE(0565 Teil 1-1)		400 V AC 400 V AC
	Rated Voltage		Test Voltage
Dissipation Factor (D.F)	Y5P	TAN δ 2.5%, measured at 1KHz \pm 10%, 1.0 ~ 5.0 V rms, 25°C	
	Y5U	TAN δ 2.5%, measured at 1KHz \pm 10%, 1.0 ~ 5.0 V rms, 25°C	
Capacitance (C)	Range	100 pF to 4700 pF. measured at 1KHz \pm 10%, 1.0 ~ 5.0 V rms, 25°C	
	Tolerance	\pm 10% \pm 20%	Y5P Y5U
Insulation Resistance (IR)	10000 M Ω min, 500 V DC		
Temperature Characteristics	Type Code	Cap.Change	Temp.Range
	Y5P	\pm 10%, max.	
	Y5U	+20%, -55% max.	
The reference temperature : 25 °C			

Y2 SERIES

INTRODUCTION:

These Ceramic Disc Capacitors are specifically designed for AC applications and meet the safety requirements of various safety standards agencies.

These capacitors are ideal for across the line and line by-pass applications

FEATURES:

- Ideal for across the line applications
- Compact size
- Cost effective product
- Safety standards recognized for AC applications



GENERAL SPECIFICATIONS:

Operating temperature range:	-25 to 85°C
Capacitance range:	10pF to 10000pF
Capacitance tolerance:	K=±10%,M=±20%
Rated voltage:	125,250 and 400 V AC.Please refer to table for approval file number.
Temperature coefficient:	±10% for B(Y5P),+30 to -80% for F(Y5V)
Dissipation factor (tan δ):	Y5P:2.5% max. at 25°C and 1KHz, 1±0.2Vrms. Y5V:5.0% max. at 25°C and 1KHz, 1±0.2Vrms.
Insulation resistance at 25°C:	10000MΩ at 500V DC for 1 minute.
Dielectric strength:	1500 V AC for 60 seconds-AC125V,AC250V 2600 V AC for 60 seconds-AC400V

CAPACITANCE AND DIMENSIONS:

When ordering safety standard recognized ceramic capacitors please use the part numbers as noted above

Rated: 125V AC, 250V AC, 400V AC for Y2

PART NUMBER	T.C.	CAP.	TOL.	DIMENSION(mm)		
				D max	F	Tmax
JY10KY5P Y2	±10% (Y5P)	10PF	K ±10%	6.5	7.5±0.8	5
to		to		6.5	7.5±0.8	5
JY82KY5P Y2		82PF		6.5	7.5±0.8	5
JY101KY5P Y2		100PF		6.5	7.5±0.8	5
JY151KY5P Y2		150PF		6.5	7.5±0.8	5
JY221KY5P Y2		220PF		6.5	7.5±0.8	5
JY331KY5P Y2		330PF		6.5	7.5±0.8	5
JY471KY5P Y2		470PF		7.5	7.5±0.8	5
JY561KY5P Y2		560PF		7.5	7.5±0.8	5
JY681KY5P Y2		680PF		7.5	7.5±0.8	5
JY102KY5P Y2		1000PF		8.5	7.5±0.8	5
JY102MY5V Y2		1000PF		6.5	7.5±0.8	5
JY152MY5V Y2		1500PF		7.5	7.5±0.8	5
JY222MY5V Y2		2200PF		9.0	7.5±0.8	5
JY332MY5V Y2	3300PF	10.5	7.5±0.8	5		
JY392MY5V Y2	3900PF	10.5	7.5±0.8	5		
JY472MY5V Y2	4700PF	11.5	7.5±0.8	5		
JY682MY5V Y2	6800PF	11.5	9.5±0.8	5		
JY822MY5V Y2	8200PF	12.5	9.5±0.8	5		
JY103MY5V Y2	10000PF	14.5	9.5±0.8	5		

Dimensions and Tolerance

B=3.0mm max for AA or 4.0mm max for A2

d=0.60mm±0.05mm

F=7.5 or 9.5±0.8mm

L=5~25mm

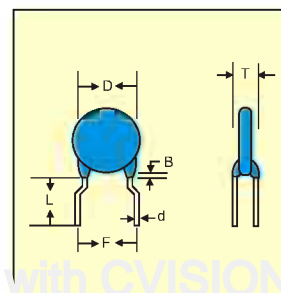

TYPE:AA

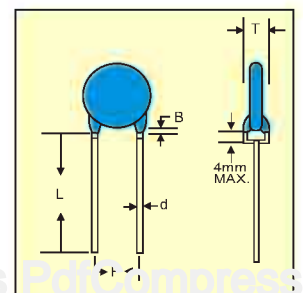

TYPE:A2

