

1. Features

- Small and light weight
- Excellent heat resistance and moisture resistance
- Taping & bulk cassette are available for automatic pick-and-place machines
- Lead free products are available

2. Applications

- All general purpose applications

3. Description

The resistors are constructed on the alumina substrate. Top electrodes are added to each end and connected with resistive paste that is applied to top surface of the alumina substrate. The resistive layer is made by resistive paste that is prepared to approach the nominal value. Laser trimming process makes the resistance value to meet the nominal value and within the tolerance.

The resistive layer is protected by primary overcoat and secondary overcoat. Marking on secondary overcoat let user to know the resistance value directly. The barrier layer is added to edge electrodes for plating with external electrode that is the main role makes the resistor mounted on PCB.

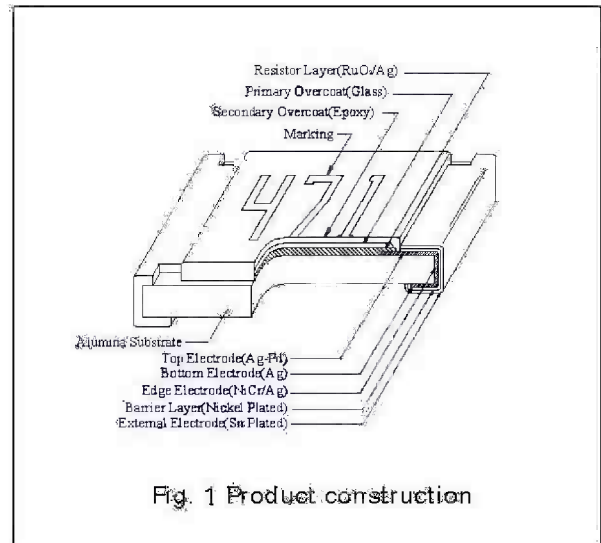

Fig. 1 Product construction

4. Quick Reference Data

Size code	0201	0402	0603	0805	1206	1210	2010	2512
Resistance tolerance	±5% ; ±1%							
Resistance range	±5%: 10Ω~1MΩ, Jumper	±1%: 10Ω~1MΩ, Jumper (<50mΩ); ±5%: 10Ω~10MΩ, Jumper (<50mΩ)						
Temperature Coefficient of Resistance (ppm/°C)	±5% ±1%	±5% ±1%	±5% ±1%					
1Ω ≤ R ≤ 10Ω	-	±200	±200					
10Ω ≤ R ≤ 1MΩ	±200	±200 ±100	±100					
1MΩ ≤ R ≤ 10MΩ	-	±200	±200					
Power rating (at 70°C)	1/20W	1/16W	1/10W	1/8W	1/4W	1/3W	3/4W	1W
Max. operation voltage (DC or RMS)	15V	50V	50V	150V	200V	200V	200V	250V
Max. overload voltage	30V	100V	100V	300V	400V	400V	400V	500V
Jumper Rated current	0.5A	1A	1A	2A	2A	2A	2A	2A
Climatic category (IEC 60068)	55/125/42			55/155/42				

5. Order information

HOW TO ORDER
 Resistors
 (RE0402J68R8KE)

(1)	(2)	(3)		(4)	(5)
RE ↓ Product RESISTORS	□□□□□	□		□□□□	Ω
	<u>SMD Size</u>	Tolerance	Code	Resistance Range	
	<u>SMD Type</u>	±1%	F	1 to 4 numbers	
	0402	±5%	J	0	
	0603			1	
	0805			10M	
	1206				
	1210				

6. Functional description

Derating curve

For resistors operate in the ambient temperature over 70°C, loading power ratio will derate in accordance with following curve.

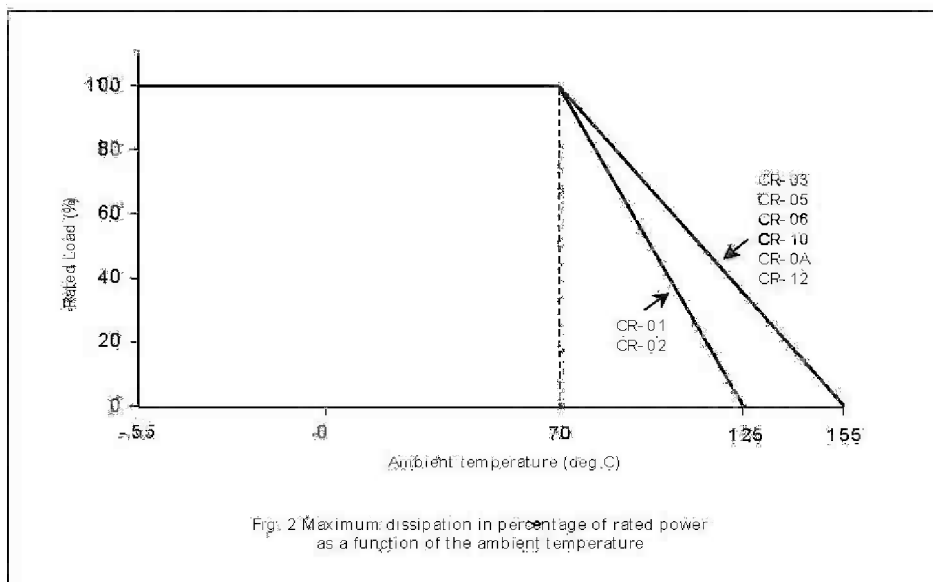

Soldering condition

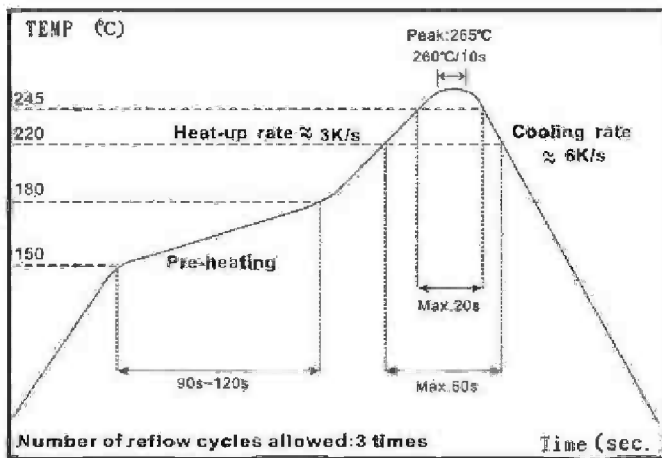

Fig.3 IR Reflow Soldering

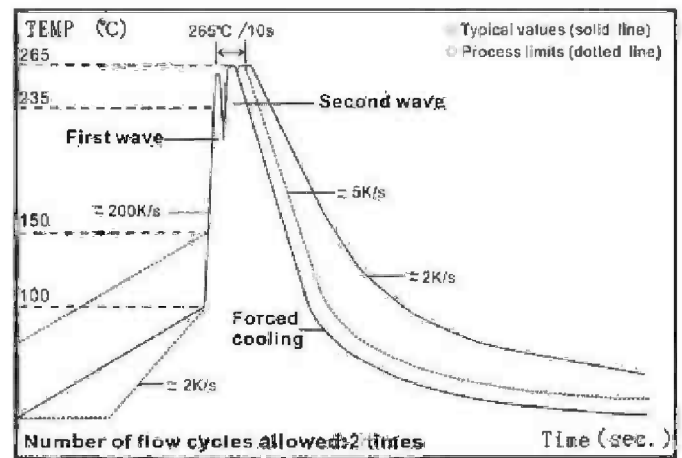

Fig.4 Wave Soldering (Flow Soldering)

7. Mechanical Data

Mass per 1000 pcs

TYPE NAME	MASS (g)
0201	0.15
0402	0.58
0603	2.02
0805	4.54
1206	8.84
1210	15.04
2010	24.39
2512	40.01

Outline

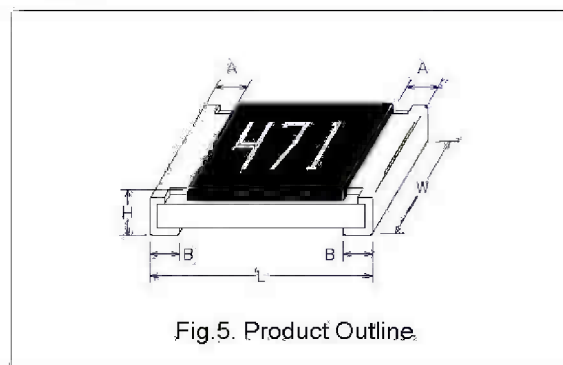

Fig.5. Product Outline.

Dimension

Type	L (mm)	W (mm)	H (mm)	A (mm)	B (mm)
0201	0.60±0.03	0.30±0.03	0.23±0.03	0.15±0.05	0.15±0.05
0402	1.00±0.05	0.50±0.05	0.35±0.05	0.20±0.10	0.20±0.10
0603	1.60±0.10	0.80±0.10	0.45±0.10	0.30±0.20	0.30±0.20
0805	2.00±0.10	1.25±0.10	0.50±0.10	0.35±0.20	0.40±0.20
1206	3.10±0.10	1.55±0.10	0.55±0.10	0.50±0.25	0.50±0.20
1210	3.20±0.20	2.60±0.15	0.55±0.10	0.50±0.25	0.50±0.20
2010	5.00±0.20	2.50±0.15	0.55±0.10	0.60±0.25	0.50±0.20
2512	6.35±0.20	3.20±0.15	0.55±0.10	0.60±0.25	0.50±0.20



Sizes 0201,0402,0603,0805,1206,1210,2010,2512

Marking

Type A: 5% product with 3 digits marking, the first two digits are significant figures; third digit is number of zeros to follow. Letter "R" is as decimal point. Letter "0" for jumper

Type B: 1% product is with 4 digits, first three digits are significant figures, fourth digit is number of zeros. Letter "R" is as decimal point. Letter "0" for jumper

Type C: **0603** ±1 % E-96 marking series as below list. (Table 2)

Type D: **0201,0402** is without marking due the size is too small.

The marking example is as table 1.

Table 1 Making code example

Type	Product	Value	Example
A	0603, ±5%	68KΩ	
	0805, ±5%		
	1206, ±5%		
	1210, ±5%		
	2010, ±5%		
B	0603, ±1%	68.1KΩ	
	0805, ±1%		
	1210, ±1%		
	2010, ±1%		
	2512, ±1%		
C	0603, ±1%	31.6Ω	
D	0201, ±1, ±5% 0402, ±1, ±5%	N/A	

Table 2. ±1% 0603 size, E-96 series marking code

Code	R value	Code	R value	Code	R value	Code	R value	Code	R value	Code	R value	Code	R value	Code	R value
01	100	13	133	25	178	37	237	49	316	61	422	73	562	85	750
02	102	14	137	26	182	38	243	50	324	62	432	74	578	86	768
03	105	15	140	27	187	39	249	51	332	63	442	75	590	87	787
04	107	16	143	28	191	40	255	52	340	64	453	76	604	88	806
05	110	17	147	29	196	41	261	53	348	65	464	77	619	89	825
06	113	18	150	30	200	42	267	54	357	66	475	78	634	90	845
07	115	19	154	31	205	43	274	55	365	67	487	79	649	91	866
08	118	20	158	32	210	44	280	56	374	68	499	80	665	92	887
09	121	21	162	33	215	45	287	57	383	69	511	81	681	93	909
10	124	22	165	34	221	46	294	58	392	70	523	82	698	94	931
11	127	23	169	35	226	47	301	59	402	71	536	83	715	95	953
12	130	24	174	36	232	48	309	60	412	72	549	84	732	96	976

This table shows the first two-digits for the three-digits EIA-96 part marking scheme.

The third character is the letter of multiplier: Y=10⁻² X=10⁻¹ A=10⁰ B=10¹ C=10² D=10³ E=10⁴ F=10⁵

8: Test And Requirements

In table 3 the tests and requirements are listed with reference relevant clause of IEC 60115-1. A short description of the test procedure is given. Essentially all tests are carried out refer to the schedule of IEC 60115-8-1. The testing also covers the requirements specified by EIA.

Table 3 Test procedure and requirements

Test Item	Test Method	Test Condition	Requirement		
			±1%	±5%	Jumper
Temperature Coefficient of Resistance(T.C.R.)	JIS C 5202 5.2 IEC 60115-1 4.8	-55°C~+125/+155 °C 20°C is the reference temperature	Within the specification		
Short Time Overload	JIS C 5202 5.5 IEC 60115-1 4.13	2.5 times RCWV or Max. overload voltage, for 5 seconds	±(1.0%+0.05Ω)	±(2.0%+0.05Ω)	<50mΩ
Insulation Resistance	JIS C 5202 5.6 IEC 60115-1 4.6	Max. overload voltage for 1 minute	≥10G		
Voltage Proof	JIS C 5202 5.7 IEC 60115-1 4.7	1.42 times RCWV (RMS) for 1 minute	no breakdown or flashover		
Substrate Bending Test	JIS C 5202 6.1 IEC 60115-1 4.33	Bending once for 5 seconds 2010, 2512 size: 2mm. Other size: 3mm	±(1.0%+0.05Ω)	±(1.0%+0.05Ω)	<50mΩ
Resistance to soldering heat	JIS C 5202 6.4 IEC 60115.4.18	260±5°C for 10 seconds	±(0.5%+0.05Ω)	±(1.0%+0.05Ω)	<50mΩ
Leaching	JIS C 5202 6.4 IEC 60115.4.18	260±5°C for 60 seconds	no leaching		
Solderability	JIS C 5202 6.5 IEC 60115-1 4.17	245±5°C for 3 seconds.	>95% coverage.		
Endurance at upper category temperature.	JIS C 5202 7.2 IEC 60115-1 2.23.2	at +125/+155 °C for 1000 hrs	±(1.0%+0.05Ω)	±(1.5%+0.10Ω)	<50mΩ
Rapid change of temperature	JIS C 5202 7.4 IEC 60115-1 4.19	-55°C to +125/+155 °C, 5 cycles	±(0.5%+0.05Ω)	±(1.0%+0.05Ω)	<50mΩ
Damp heat with load	JIS 5202 7.9	40±2°C, 90~95% R.H. or Max. working voltage for 1000 hrs with 1.5hrs "ON" and 0.5 hrs "OFF"	±(2.0%+0.10Ω)	±(3.0%+0.10Ω)	<100mΩ
Endurance	JIS C 5202 7.10 IEC 60115-1 4.25.1	70±2°C, or Max. working voltage for 1000 hrs with 1.5 hrs "ON" and 0.5 hrs "OFF"	±(2.0+0.10Ω)	±(3.0+0.10Ω)	<100mΩ

Note:

RCWV : Rated continuous working voltage .

$$RCWV = \sqrt{\text{Rated power} * \text{Resistance value}}$$

Packaging

Packaging Methods

Type (unit: piece)	Paper Tape			Embossed Tape	Bulk Cassette
	7" (178mm)	10" (254mm)	13" (330mm)	7"(178mm)	
0201	10000	20000	40000	-	
0402	10000	20000	40000	-	50000
0603	5000	10000	20000	-	25000
0805	5000	10000	20000	-	10000
1206	5000	10000	20000	-	5000
1210	5000	10000	20000	-	
2010,2512	-	-	-	4000	-

Paper Tape

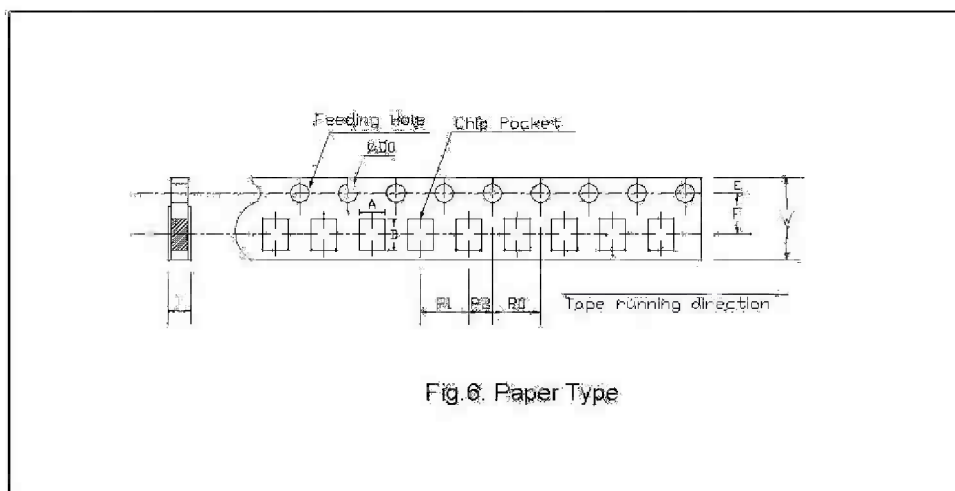

Fig.6. Paper Type

Type	A	B	W	E	F	P0	P1	P2	AD0	T
0201	0.38±0.05	0.68±0.05	8.0±0.2	1.75±0.1	3.5±0.05	4.0±0.1	2.0±0.05	2.0±0.05	1.5 ^{+0.12/0}	0.42 ^{+0.2/0}
0402	0.65±0.1	1.15±0.1								0.45±0.1
0603	1.10±0.1	1.90±0.1								0.70±0.1
0805	1.60±0.1	2.40±0.2					0.85±0.1			
1206	1.90±0.1	3.50±0.2					0.85±0.1			
1210	2.80±0.1	3.50±0.2					0.85±0.1			

Unit: mm



Embossed Plastic Tape

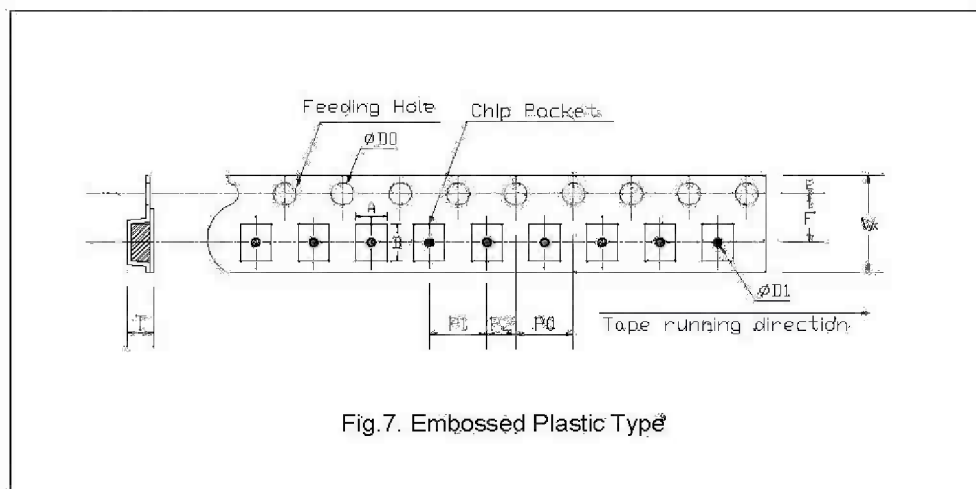
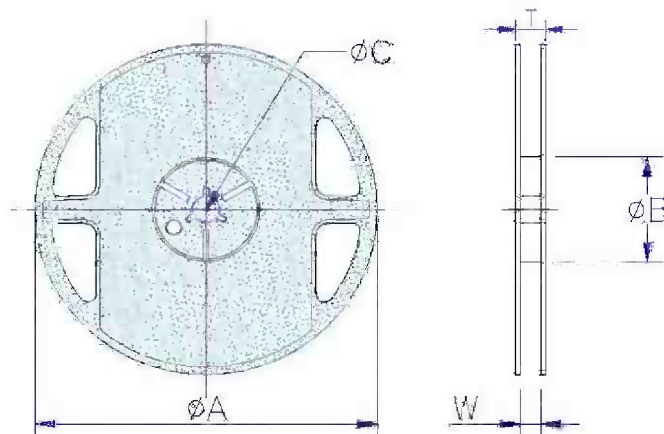

Fig. 7. Embossed Plastic Type

Type	A	B	W	E	F	P0	P1	P2	φ D0	φ D1	T
2010	2.8±0.2	5.5±0.2	12±0.3	1.75±0.1	5.5±0.50	4.0±0.1	4.0±0.1	2.0±0.05	1.5 ^{+0.1/-0}	1.5 ^{+0.25/0}	Max1.2
2512	3.5±0.2	6.7±0.2	12±0.3	1.75±0.1	5.5±0.50	4.0±0.1	4.0±0.1	2.0±0.05	1.5 ^{+0.1/-0}	1.5 ^{+0.25/0}	Max1.2

Unit: mm

Reel Specification



Unit:mm

Style	Packing	Tape width	Reel Diameter	φA	φB	φC	W	T
0201 0402 0603 0805 1206 1210	Paper	8 mm	7 inch	180 ^{+0.5}	60 ^{+1.0}	13.0±0.2	9.0±0.3	11.4±1
10 inch			254±1	100±1	13.0±0.2	9.5±0.5	13.5±1	
13 inch			330±1	100±1	13.0±0.2	9.5±0.5	13.5±1	
2010 2512	Embossed	12 mm	7 inch	180 ^{+0.5}	60 ^{+1.0}	13.0±0.2	13.0±0.5	13.4±1