

Thick Film Array Chip Resistors- RA series

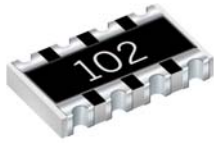
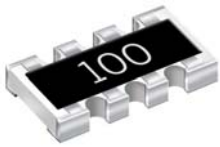

Features:

- Small size and light weight.
- Reduction of assembly costs and matching with placement Machines.
- Reliability, High quality.
- Suitable for both IR reflow soldering and wave soldering.

Applications:

- Entertainment
- Computer & relative products
- Communication equipment
- Power equipment
- Measuring instrument

Dimensions

4P2R Convex Array

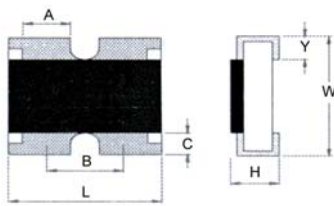

Equivalent Circuit Diagram

4P2R

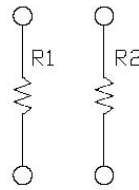

$$R1=R2$$

8P4R

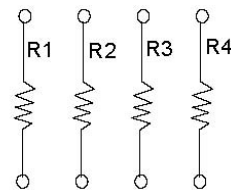

$$R1=R2=R3=R4$$

8P4R Convex Array

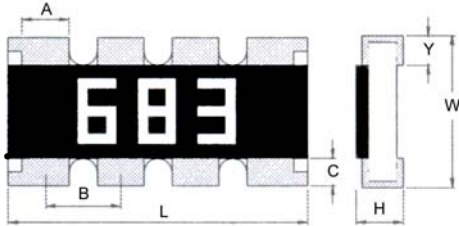

Concave Array

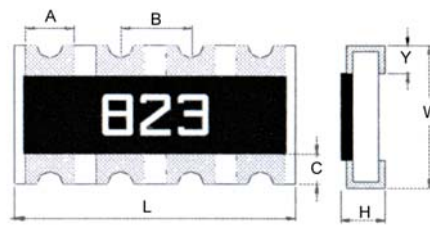

Unit: mm

TYPE	Number of Resistors	L	W	H	A	B	C	Y
RA04	2	1.00±0.10	1.00±0.10	0.35±0.10	0.25±0.10	0.65±0.05	0.20±0.10	0.25±0.10
RA02	4	2.00±0.20	1.00±0.15	0.45±0.10	0.30±0.10	0.50±0.10	0.22±0.15	0.22±0.15
RA03	4	3.20±0.20	1.60±0.15	0.55±0.10	0.50±0.15	0.80±0.10	0.30±0.15	0.30±0.15
RA03-C	4	3.20±0.20	1.60±0.15	0.55±0.10	0.50±0.15	0.80±0.10	0.30±0.15	0.40±0.15

Part Numbering

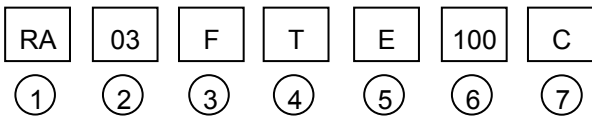

① Product Type

Product Type	Type
RA	Thick Film Chip Resistors Array

② Dimensions (LxW)

Codes	Dimensions (LxW)	EIA
04	1.0×1.0mm	0402×2
02	2.0×1.0mm	0402×4
03	3.2×1.6mm	0603×4

③ Resistance Tolerance

Codes	Resistance Tolerance
F	±1 %
J	±5 %

④ Packaging

Codes	Type
T	Taping Reel

⑤ TCR

Codes	Type
F	±200ppm
-	No Specified

⑥ Resistance

Codes	Type
100	10Ω
49R9	49.9Ω
221	220Ω
102	1000Ω
492	4900Ω
103	10000Ω

⑦ Special

Codes	Type
	Convex
C	Concave

Electrical Characteristics Specifications

Type	Item	Power Rating / Rated Current	Operating Temp. Range	Max Working Voltage	Max Overload Voltage	Number of Resistors	Resistance Tolerance		Resistance Range	TCR (PPM/°C)
RA04 Jumper	1/16W 1A	-55 ~ +125°C	25V	50V	2	±1% ±5%	E24 E96 -	10Ω~1MΩ 0Ω	±200	
RA02 Jumper	1/16W 1A	-55 ~ +125°C	25V	50V	4	±1% ±5%	E24 E96 -	10Ω~1MΩ 0Ω	±200	
RA03 Jumper	1/10W 1A	-55 ~ +125°C	50V	100V	4	±1% ±5%	E24 E96 -	10Ω~1MΩ 0Ω	±200	
RA03-C Jumper	1/16W 1A	-55 ~ +125°C	50V	100V	4	±1% ±5%	E24 E96 -	10Ω~1MΩ 0Ω	±200	

Packaging

Reel Specifications & Packaging Quantity

Unit :mm

Series	ΦA	ΦB	ΦC	W	T	Paper Tape (EA)
RA04	180+0/-3	60min.	13.0±1	9.0±1.0	11.4±2.0	10000
RA02	180+0/-3	60min.	13.0±1	9.0±1.0	11.4±2.0	10000
RA03	180+0/-3	60min.	13.0±1	9.0±1.0	11.4±2.0	5000

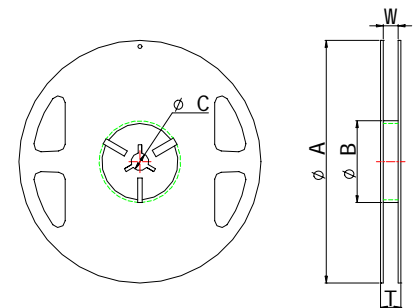

Paper Tape Specifications

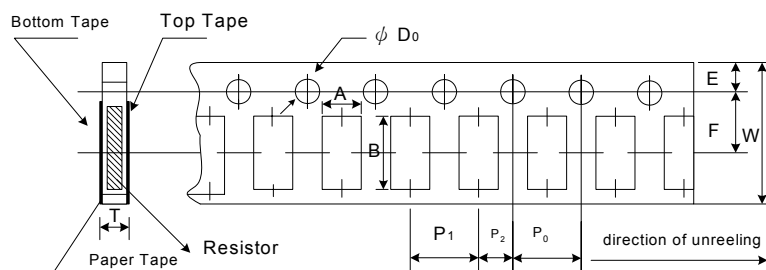

Unit :mm

Series	A	B	W	F	E	P ₁	P ₂	P ₀	ΦD ₀	T
RA04	1.2±0.1	1.2±0.1	8.0±0.2	3.50±0.05	1.75±0.01	2.00±0.05	2.00±0.05	4.00±0.10	1.50+0.1/-0	0.85±0.1
RA02	1.2±0.1	2.2±0.2	8.0±0.2	3.50±0.05	1.75±0.01	2.00±0.05	2.00±0.05	4.00±0.10	1.50+0.1/-0	0.85±0.1
RA03	2.0±0.1	3.6±0.1	8.0±0.2	3.50±0.05	1.75±0.01	4.00±0.05	2.00±0.05	4.00±0.10	1.50+0.1/-0	0.85±0.1

Environmental Characteristics

Item	Specification		Test Method
	1%	5%	
Temperature Coefficient of Resistance	As Spec.		MIL-STD-202F Method 304 +25/-55/+25/+125/+25°C
Short Time Overload	±(1.0%+0.05Ω)	±(2.0%+0.05Ω)	RCWV*2.5 or Max Overloading Voltage · 5 seconds
	Jumper <50mΩ		
Insulation Resistance	≥ 10GΩ		MIL-STD-202, Method 302 RCOV for 1minute
Voltage Proof	No breakdown or flashover		MIL-STD-202F Method 301 Apply Max Overload Voltage for 1 minute
Resistance to Soldering Heat	±(0.5%+0.05Ω)	±(1.0%+0.05Ω)	MIL-STD-202F Method 210E 260±5°C, 10±1second
	Jumper <50mΩ		
Solderability	>95% Coverage		MIL-STD-202F Method 208H 245±5°C, 5±0.5 second
Resistance to Dry Heat	±(1.0%+0.05Ω)	±(1.5%+0.10Ω)	JIS-C-5202-7.2 125°C, 96 hrs. without load
	Jumper <50mΩ		
Thermal Shock	±(0.5%+0.05Ω)	±(1.0%+0.05Ω)	MIL-STD-202F Method 107G -55°C~150°C, 5 cycles
	Jumper <50mΩ		
Humidity (steady state)	±(2.0%+0.10Ω)	±(3.0%+0.10Ω)	MIL-STD-202F, Method 103B 40±2°C, 90~95% R.H. for 1000 hrs, without load
	Jumper <50mΩ		
Load Life	±(2.0%+0.1Ω)	±(3.0%+0.1Ω)	MIL-STD-202F Method 108A RCWV · 70°C · 1.5 hours on · 0.5 hrs off Total 1000~1048 hrs.
	Jumper <50mΩ		